

**INTERBUS**

**PMA**

# KS 98 / IBS

## INTERBUS option for KS 98

### INTERBUS remote bus

**Cyclic transmission of up to  
24 input and 24 output variables**

**Free definition of data content**

**Transmission of process and parameter data**

**Inputs and outputs as decentral IO**

**cULus certified**

*advanced line*

#### DESCRIPTION

With its INTERBUS option, the KS 98-IBS can be connected to INTERBUS networks. This allows the unit to be integrated as a stand-alone module for control, sequencing, and visualization in de-centralized PC systems.

The supervisory device (PLC, IPC) transmits data to the KS 98 cyclically, that can be linked freely into the Engineering. This data involves e.g. set-points for controllers, recipes, correction factors, or even parameters. The functions implemented in the KS 98 are executed fully independently. This ensures utmost process reliability and safety together with fast projecting and commissioning.

#### DISPLAY AND OPERATION

Via its fully graphic display, the KS 98 provides a clear, on-site indication of all process values. If required, switch-over to local operation is possible. For example this enables the KS 98 to be commissioned without extensive previous programming of the PLC or the supervisory system. In addition, the Engineering Tool ET/KS 98plus is available for assistance. It is simply connected via the front-panel port, and serves for configuration, parameter setting, and operation of the KS 98. By means of the built-in trend display, the quality of the control results can be evaluated.

#### DE-CENTRALIZED I/O

Complete applications can be implemented with the KS 98, consisting of control and sequencing (PLC) functions, plus full visualization. Furthermore, all inputs and outputs are accessible via the INTERBUS. If required, this also allows emergency operation, i.e. control of the outputs via the KS 98, if the supervisory system should fail.

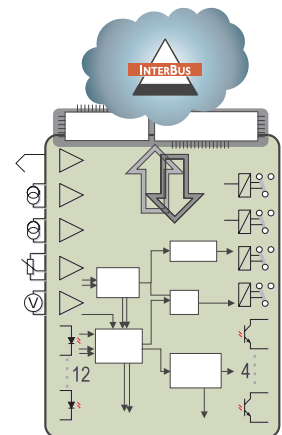

The basic functions of the KS 98-IBS, such as inputs/outputs, control functions, etc., are described in the KS 98 data sheet, Order no. 9498 737 32113.

## TECHNICAL DATA

INTERBUS port according to EN 50 252  
Vol. 2

4-wire remote bus RS 485

### DATA FORMAT

Real values are transmitted in the 16-bit fixed comma format (FIX), with one decimal character.

### PROCESS DATA CHANNEL

The process data channel (PD) can be structured with different lengths and contents.

By means of the Engineering Tool ET/KS98plus (Version 3.2 upwards), functions DPREAD and DPWRIT can be selected up to four times each. By combining internal signals with the inputs/outputs of these functions, all kinds of signals can be transmitted on the INTERBUS.

#### Structure A

without PCP: Ident code = 51, PDL=64 bit

with PCP: Identcode = 240, PDL = 64 bit

Direct transmission of digital and analog values from the I/O memory area of the master. This is done by addressing the DPREAD function (Block no. 1) and the DPWRIT Function (Block no. 11).

Byte	KS 98 ⇒ INTERBUS	INTERBUS ⇒ KS 98
0 1	Status word	fixed 0
2 3	d1...d16	z1...z16
4 5	x1	y1
6 7	x2	y2

#### Structure B

Identcode = 240, PDL = 128 bit

Direct transmission of digital and analog values from the I/O memory area of the master. This is done by addressing the DPREAD function (Block no. 1) and the DPWRIT Function (Block no. 11).

Byte	KS 98 ⇒ INTERBUS	INTERBUS ⇒ KS 98
0 1	Status word	fixed 0
2 3	d1...d16	z1...z16
4 5	x1	y1
6 7	x2	y2
8 9	x3	y3
10 11	x4	y4
12 13	x5	y5
14 15	x6	y6

Fig. 1 Free definition of internal variables via functions DPREAD and DPWRIT:

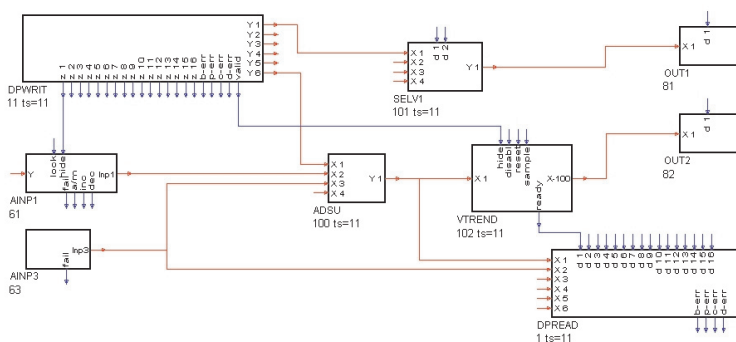

#### Structure C

Identcode = 51, PDL = 48 bit

Multiplex transmission of analog values. This structure provides access to all four DPWRIT and all four DPREAD functions.

Byte	KS 98 ⇒ INTERBUS	INTERBUS ⇒ KS 98
0 1	Status word	fixed 0
2 3	Index-Read	Index-Read
4 5	Index-Write	Index-Write
6 7	Val-Read	Val-Write

Index-Read allows 24 analog values to be addressed. The addressed value is returned in Val-Read.

Index-Read	DPREAD Block-no.	Input
1 2 3 4 5 6 7	1	d1...d16 x1 x2 x3 x4 x5 x6
8 9 10 11 12 13 14	2	d1...d16 x1 x2 x3 x4 x5 x6
15 16 17 18 19 20 21	3	d1...d16 x1 x2 x3 x4 x5 x6
22 23 24 25 26 27 28	4	d1...d16 x1 x2 x3 x4 x5 x6

Index-Write allows 24 analog values to be addressed. The value stored in Val-Read is returned according to the addresses in Index-Write, as follows:

Index-Write	DPWRIT Block-no.	Output
1 2 3 4 5 6 7	11	z1...z16 y1 y2 y3 y4 y5 y6
8 9 10 11 12 13 14	12	z1...z16 y1 y2 y3 y4 y5 y6
15 16 17 18 19 20 21	13	z1...z16 y1 y2 y3 y4 y5 y6
22 23 24 25 26 27 28	14	z1...z16 y1 y2 y3 y4 y5 y6

#### Status word

General information on errors and status

#### CONNECTIONS

The bus is connected via a D-type connector at the rear.

- Incoming bus: male
- Outgoing bus: female

#### Cable

Cable according to EN 50 254-2-2

Max. 400 m of cable are permitted between two devices on the bus.

## DIAGNOSIS

INTERBUS diagnostic LEDs on the rear (see Fig. 3).

Example of clear text display on the KS 98:

```

Status INTERBUS
-----
Interface mod= O.K.
Master access= O.K.
Bus state     = RUN
PCP activat. = off
End
    
```

The functions DPREAD and DPWRIT have access to status outputs that can be used for error detection. Corresponding individual signalling functions can be configured in the Engineering.

Certification: by INTERBUS club  
PCP channel: available

## PERMISSABLE TEMPERATURES

For specified accuracy: 0...50°C

For operation: 0...55°C

Storage and transport: -20...60°C

Reduced operating temperature in conjunction with standard or modular Option C: 0...45°C !

## POWER CONSUMPTION

90...253VAC: 14,2VA / 8,5W

24V AC: 14,2VA / 8,5W

24V DC; 14,2W

Fig. 2 Connection diagram KS 98/IBS:

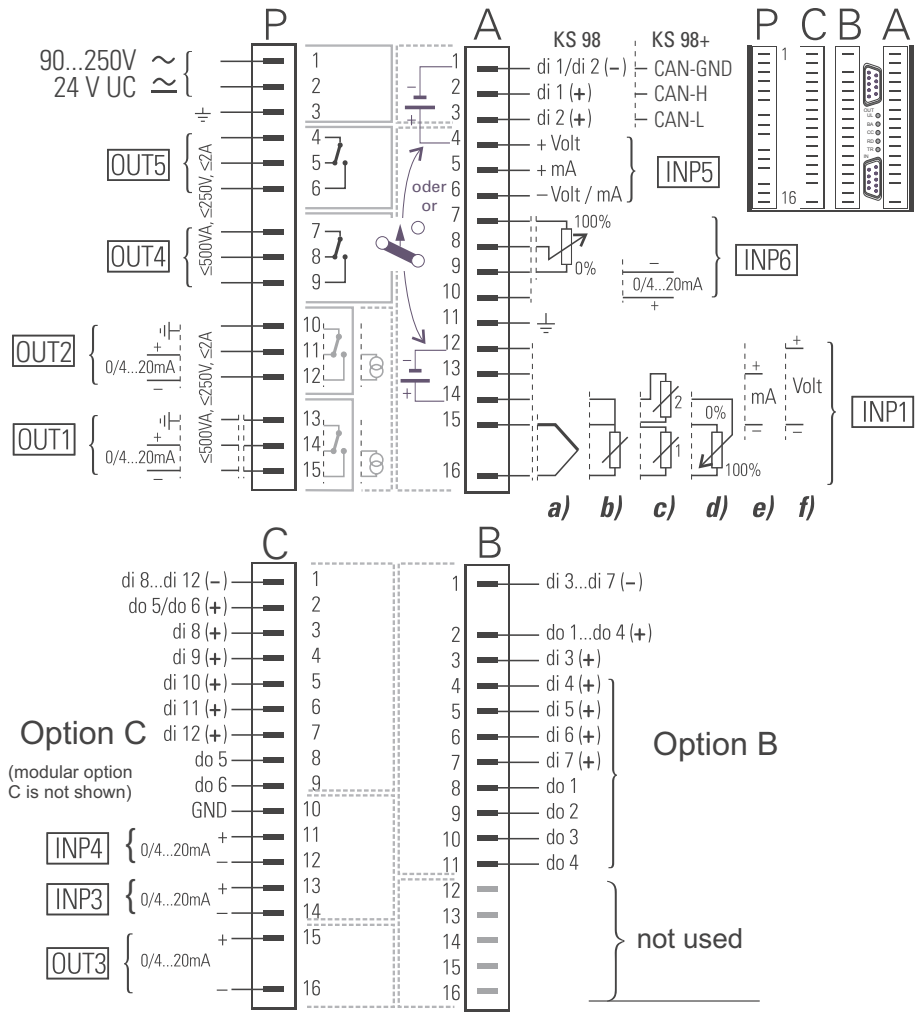

Fig. 2 Einbaumaße (in mm):

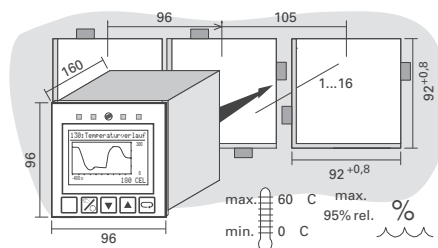
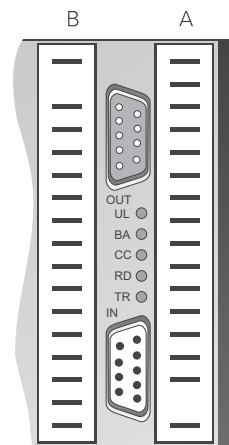

Fig. 3 Connection and LEDs INTERBUS



## ORDERING INFORMATION KS 98 / KS 98+ WITH INTERBUS

Please mind the footnotes!

Multi-function unit	9	4	0	9			0		XXX
Flat pin connectors <sup>2)</sup>	7								
Screw terminal connectors	8								
KS 98 Standard				6					
KS 98 with 2-wire power supply				7					
KS 98+ with CANopen I/O <sup>3)</sup>				8					
90..250V AC, 4 Relays					3				
90..250V AC, 2 Relays + 2 current outputs					5				
24V UC, 4 Relays					7				
24V UC, 2 Relays+ 2 current outputs					9				
No interface						0			
TTL-interface + di/do						1			
RS422 + di/do + clock						2			
PROFIBUS DP + di/do						3			
InterBus + di/do						4			
No extension							0		
INP3, INP4, OUT3, di/do							1		
INP3 (mV), INP4, OUT3, di/do							2		
Motherboard without modules inserted							3		
Motherboard ordered modules inserted							4		
Standard configuration								0	
Customer specific configuration								9	
CE-certified									1 XXX
cULus-certified (Standard or specific membrane) <sup>1)</sup>									U XXX

1) cULus with screw terminals only!

cULus not possible with InterBus!

2) not with cULus approval!

3) RM200 modules not included in cULus approval!

### Accessory Equipment

### Order no.

Engineering Set ES/KS98 INTERBUS	german	9407-999-10211
Engineering Set ES/KS98 INTERBUS	english	9407-999-10201

Engineering Set consists of the manual for INTERBUS and a diskette with all required files and examples for the tool CMD from Phoenix Contact.



### PMA

Prozess- und Maschinen- Automation GmbH  
 P.O Box 31 02 29  
 D - 34058 Kassel  
 Tel.: +49 - 561 - 505 1307  
 Fax: +49 - 561 - 505 1710  
 E-mail: mailbox@pma-online.de  
 Internet: http://www.pma-online.de

### Your local representative