

PMA Prozeß- und Maschinen Automation GmbH 1997. Printed in Germany
All rights reserved. No part of this document may be reproduced
or published in any form or by any means without prior written
permission by the copyright owner.

A publication of PMA Prozeß- und Maschinen- Automation GmbH

Subject to change without notice.

PMA Prozeß- und Maschinen- Automation GmbH
P.O. Box 31 02 29
D 34058 Kassel
Germany

Restriction of warranty:

No warranty is given for the complete correctness of this manual, because errors can never be avoided completely despite utmost care. Hints are always welcome and gratefully accepted.

Contents

1 Introduction.....	5
1.1 Basic structure	5
1.2 Input.....	5
1.3 Functions	6
1.4 Output.....	6
2 Input signal processing.....	7
2.1 Measurement value pre-processing.....	7
2.2 Measuring frequency	7
2.3 Sensor types	7
2.3.1 Thermocouples	7
2.4 mV signals (DC)	8
2.5 V signals (DC)	8
2.6 Resistance thermometer	8
2.7 Measurement value correction.....	8
2.7.1 Application examples:	9
2.7.2 Input signal distribution	9
3 Controller block diagram.....	10
3.1 Sequence control	10
4 Set-point functions	11
4.1 Set-point control	11
5 Controller statuses and priorities	12
5.1 Priority 0 automatic (low).....	12
5.2 Priority 1 Tune, run.....	12
5.3 Priority 2 Tune, error	12
5.4 Priority 3 sensor break.....	13
5.5 Priority 5 manual	13
5.6 Priority 7 Y_track.....	13
5.7 Priority 8 controller off (high).....	14
6 Controller self-tuning (RSE).....	16
6.1 Preparations for controller self-tuning:	16
6.2 Process at rest	16
6.2.1 Selecting the stable correcting variable	16
6.2.2 Start from automatic mode.....	17
6.2.3 Start from manual mode.....	17
6.2.4 Self-tuning start with heating (2-point and 3-point stepping controller)	17
6.2.5 Self-tuning procedure with heating and cooling processes: (3-point contr.)	18
6.2.6 Set-point monitoring	18
6.2.7 Group optimization of several controllers.....	18
6.2.8 Group self-tuning start	18
6.2.9 Group self-tuning stop.....	18
6.2.10 Starting the heating attempt of all group controllers in common	18
6.2.11 Common start of the cooling attempt for all 3-point heating/cooling controllers of the group.....	19
6.2.12 Signification of self-tuning messages.....	20
7 Controlled adaptation	22
7.1 Control function parameters	22
8 Signaller	23
9 Two-point controller	24
10 Three-point controller DPID.....	26

11 Three-point stepping controller	28
12 Cascade control	31
12.1 Configuration of a simple cascade with one master and one slave	31
12.2 Controller behaviour with switch-over	32
12.2.1 Switching over the master from:	32
12.2.2 Switching over the slave :	32
12.3 Interrupting the cascade operation.....	32
12.4 Cascade control example with up to 15 slave controllers	33
13 Start-up circuit	35
14 Mean value formation for the output hold function.....	38
15 Alarm processing.....	39
16 Configuration	40
16.1 General	40
16.2 Main configuration groups	40
16.2.1 C100 Main controller configuration (adjustable for each controller)	40
16.2.2 C101 Additional controller configuration (<i>adjustable for each controller</i>)	41
16.2.3 C180 Analog signal allocation	42
16.3 Inputs.....	42
16.3.1 C200 Main configuration	43
16.3.2 Input scaling	43
16.3.3 C202 Span end input scaling.....	44
16.3.4 C205 Additional configuration.....	44
16.3.5 C210 External temperature compensation.....	45
16.3.6 C213 Sensor failure	45
16.3.7 C214 Filter time constant	45
16.4 Configuration examples	46
16.4.1 Thermocouple.....	46
16.4.2 Resistance thermometer	46
16.4.3 Voltage and standard current	46
16.4.4 C600 Type of alarm	46
16.4.5 C700 controller self-tuning (RSE, Tune).....	47
16.4.6 Additional functions.....	47
16.4.6.1 C900 Baudrate of COM1 PC interface	47
16.4.6.2 C901 Address of COM1.....	48
16.4.6.3 C902 Baudrate of COM2 bus interface	48
16.4.6.4 C903 Address of COM2.....	48
16.4.6.5 C904 Mains frequency	49

1 Introduction

The functions of multi-function controller KS 816 are described on the following pages. Not all functions can be used for each particular instrument version, because some hardware and software functions preclude each other due to the instrument configuration (e.g. 8 channels configured as three-point stepping controllers, and digital inputs).

1.1 Basic structure

The basic KS 816 structure for handling the control functions is shown in the drawing below. It is divided into three main groups:

- Input
- Functions
- User interface (the user interface function is not described in this manual).

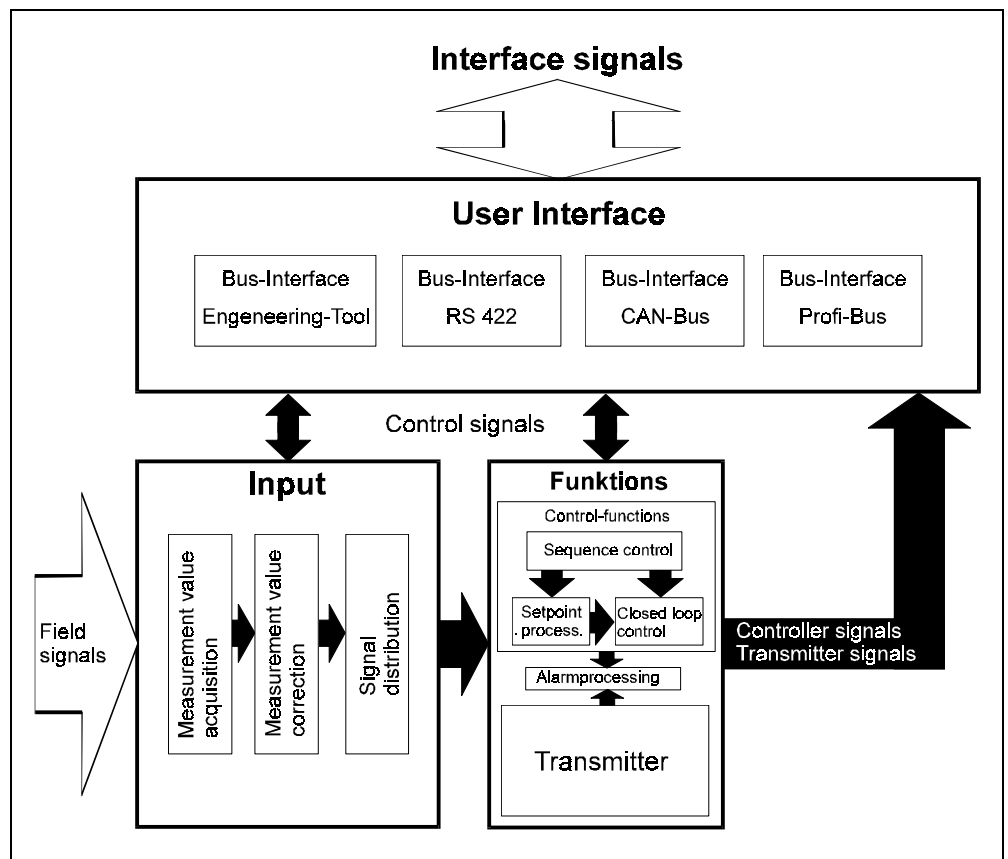

1.2 Input

Measurement value acquisition

The field input signals are acquired and converted dependent of adjusted sensor type.

Measurement value correction

This block is used for measurement value correction (zero offset, suppression, gain adjustment).

Signal distribution

The conditioned input signals (together with the relevant control parameters) are passed to the controller cyclically.

1.3 Functions

Sequence control

The sequence control describes the statuses and priorities in the control algorithm and the conditions and signals for other function statuses.

Closed-loop control

The correcting variable is calculated dependent of selected controller configuration and adjusted control parameters.

Set-point processing

Dependent of the instrument configuration, various functions for generation of the valid (effective) set-point (Weff) for the control function are selected.

Alarm processing

Each individual controller has various alarm functions each with four trigger points. Allocating the alarms to various alarm functions is possible via configuration.

1.4 Output

Signal post-processing

The controller calculation result will still undergo (user-defined) post-processing, e.g. a minimum duty cycle must be taken into account.

Signal output

The output value of the relevant controller is output and stored until the next cycle.

KS816 does not have controller outputs in the conventional sense. The calculated switching statuses of the individual controllers are output to the PLC via the bus. The final elements must be actuated via a digital output card.

2 Input signal processing

2.1 Measurement value pre-processing

Before being used in the controller functions, all measurement signals must be conditioned accordingly. Measurement value processing converts the hardware signals into numeric values, which are converted into physical signals (°C, °F, ...) by linearization/scaling via measurement value processing. Sensor monitoring (break, overflow, wrong polarity) is also provided by measurement value processing.

2.2 Measuring frequency

As analog/digital conversion of the input circuit is in common for all 16 controllers, the individual controller inputs are measured cyclically. Each controller input is measured twice per second.

2.3 Sensor types

The sensor type can be determined for each controller during configuration. Determination of different sensor types is also possible.

Analog measurement value acquisition includes the following values:

Process value measurement for 16 controllers.

- thermocouple,
- mV signals (DC)
- V signals (DC)
- resistance thermometer,
- standard 0/4...20 mA signals (DC)

2.3.1 Thermocouples

The following thermocouple types to DIN/EN 60584 can be connected:

Thermocouple type	Thermocouple material	Conductor colour	Range
L	Fe/Cu-Ni (IOEC)	blue	0... 900°C
J	Fe/Cu-Ni (DIN)	black	0... 900°C
K	Ni-Cr/Ni	green	0...1350°C
N	Nicrosil/Nisil	pink	0...1300°C
S	Pt-10Rh/Pt	orange	0...1760°C
R	Pt-13Rh/Pt	white	0...1760°C
T	Cu/Ni-Cu	brown	0... 400°C
W	W5Re/W26Re	not determined	0...2300°C
E	Ni-Cr/Cu-Ni	violet	0...1000°C

The lower measurement limit of KS 816 is 0 mV for all thermocouple types, i.e. 0°C, or 32°F. The upper measurement limit is the upper operating temperature of the relevant thermocouple type.

The thermocouples are monitored for wrong polarity and break.

Wrong polarity monitoring responds, when the wrong polarity voltage corresponds to a temperature of 30°C.

2.4 mV signals (DC)

The same input as for thermocouple (INxT+) is used for DC voltage up to 100mV.

Only the configuration is different:

- span -100mV...+100 mV
- no monitoring for wrong polarity
- no break monitoring

2.5 V signals (DC)

Via a separate input (InxU), -10V...+10V signals can be processed.

Monitoring for break/wrong polarity is provided.

Monitoring for break and wrong polarity is not possible.

2.6 Resistance thermometer

PT 100 resistance thermometers to DIN/IEC 751 can be connected in 2 or 3-wire circuit. (using 2-wire connection is not recommendable.)

The lower measurement limit is -100°C

The upper measurement limit is +850°C.

The thermometer current is approx. 0,25 mA.

The resistance thermometer is monitored for break and short circuit. With short circuit, the resistance (sensor incl. leads) < 48 Ω (-130°C).

2.7 Measurement value correction

A method which permits zero offset, gain adjustment or a combination of both by means of 4 parameters is used.

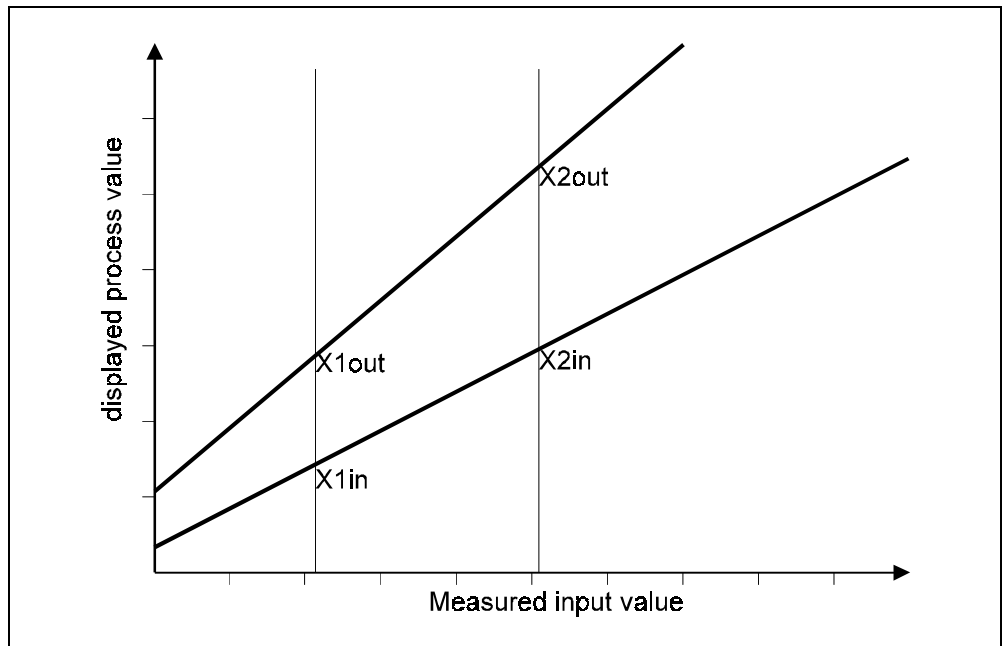

The parameters can be determined for any working points:

- | | |
|-------|---------------------------------------|
| x1in | old displayed start value |
| x1out | corrected start value to be displayed |
| x2in | old displayed end value |
| x2out | corrected end value to be displayed |

2.7.1 Application examples:

Any units are possible.

1. Gain adjustment

The straight line from 0 ... 900 shall be 105 instead of 100 in working point 100.
 $x_{1in} = 0$, $x_{1out} = 0$, $x_{2in} = 100$ and $x_{2out} = 105$.

With an input value of 900, the output value is $900 \times 1,05 = 945$

2. Zero offset

The straight line from 0 ... 100 shall be shifted upwards by 5:
 $x_{1in} = 0$, $x_{1out} = 5$, $x_{2in} = 100$, $x_{2out} = 105$

3. Combined gain adjustment and zero offset

The straight line from 0 ... 100 shall be changed into 5 ... 112:
 $x_{1in} = 0$, $x_{1out} = 5$, $x_{2in} = 100$ and $x_{2out} = 112$.

e.g. with input value 200, the output value is 219.

2.7.2 Input signal distribution

Input signal distribution is according to the following table:

Hardware input signal	Controller input signal	Remark
In1...IN16	X1...X16	Controller process values

3 Controller block diagram

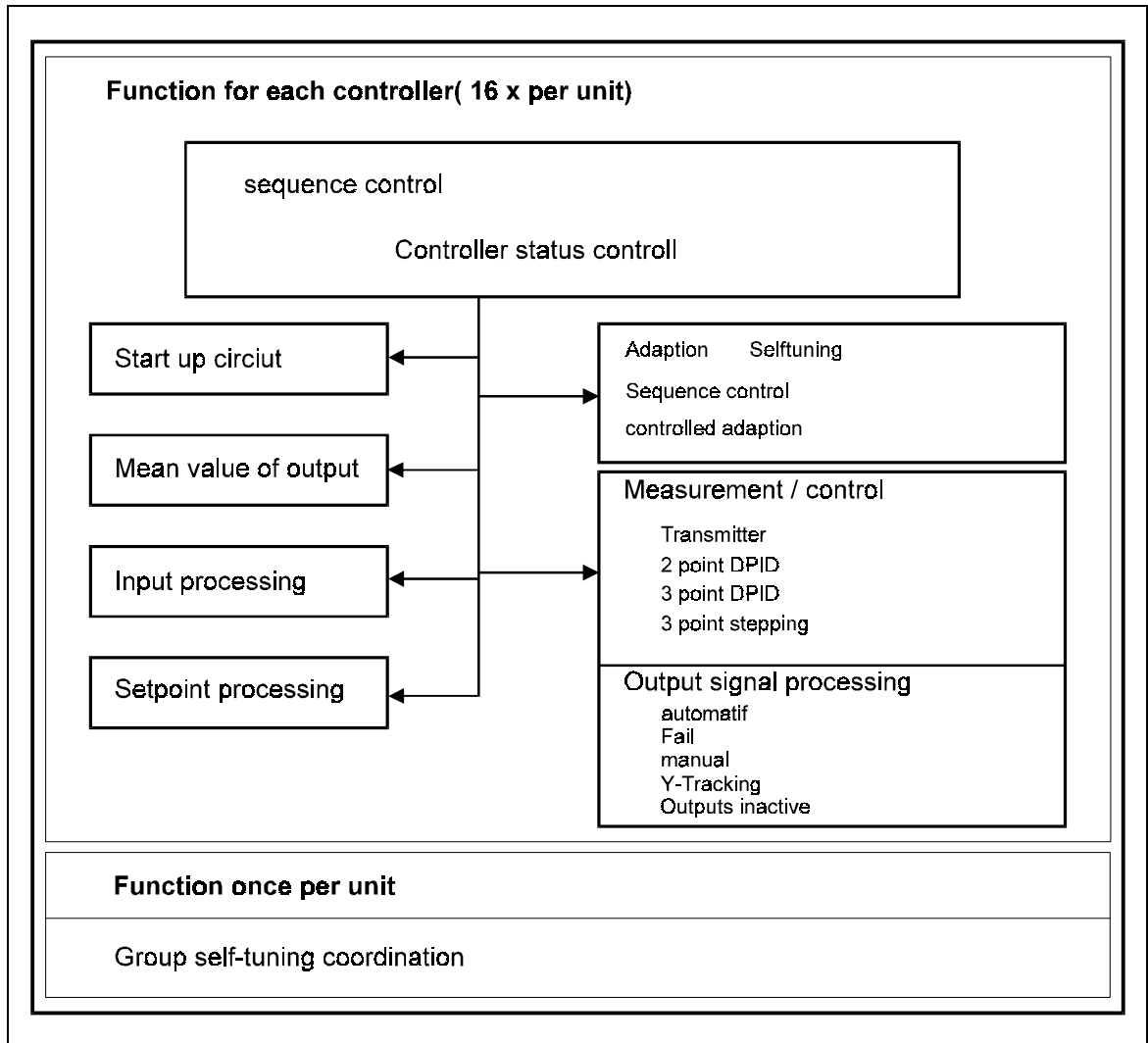

3.1 Sequence control

Several controller statuses which can be switched over via the interface are possible (configuration C500).

After a mains failure, the operating status is according to the interface signal stored last (EEPROM contents).

4 Set-point functions

4.1 Set-point control

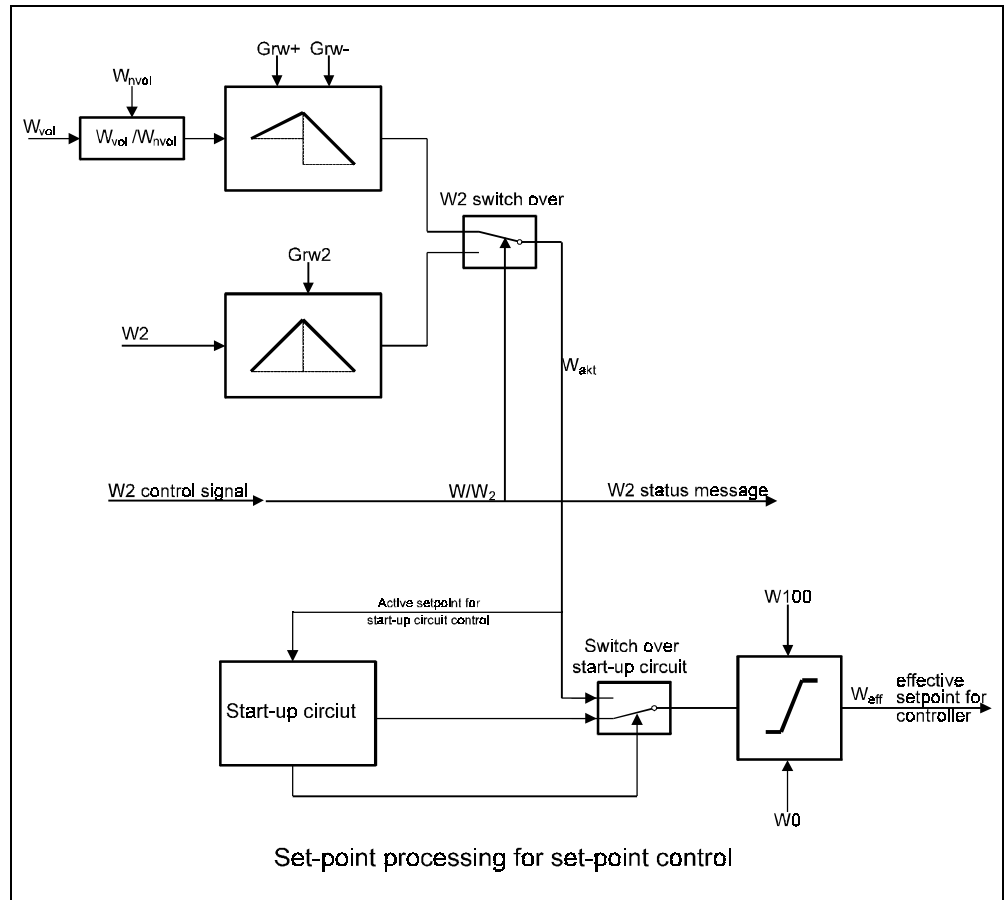

The effective set-point for KS 816 undergoes various pre-processings, before it is used for the control algorithm.

When switching on the instrument, the non-volatile set-point W_{nvol} is effective, i.e. $W_{vol} = W_{nvol}$.

„volatile“ refers to the data loss with supply voltage failure.

The adjustable set-point gradient $Grw+$ is effective, when the set-point is increased. A step increase of the set-point is converted into a ramp by this gradient.

$Grw2$ works accordingly with set-point reduction.

$Grw2$ is effective when switching over to and from the 2nd set-point. This gradient is equal for increasing and decreasing step change.

The second set-point is „non-volatile“ with power failure“.

Set-point/2nd set-point switch-over is as follows:

When activating, the 2nd set-point has priority! When the 2nd set-point is effective, a status message is output via the interfaces.

This active set-point W_{akt} is evaluated also by the start-up circuit, which decides which set-point is used for start-up according to a separate algorithm: active set-point W_{akt} or a set-point calculated by the start-up circuit.

Before being passed to the controller, the set-point is limited to the „adjustment range“.

W_0 is the lower limit and W_{100} is the upper limit of the set-point adjustment range. These limits are absolute and cannot be exceeded.

The priorities are sorted in ascending order (0=low; 7=high)

5 Controller statuses and priorities

The priorities are sorted in ascending order (0=low; 7=high)

5.1 Priority 0 automatic (low)

The controller is in automatic mode (control mode). Set-points can be pre-determined.

5.2 Priority 1 Tune, run

Self-tuning is active and handles the required procedure independently.

Start is via the interface with Ostart = 1 and is stopped with Ostart = 0.

The start / stop signal can be generated also internally by the control function with group self-tuning configured (see section Group self-tuning).

Function block controller type no.: 91, function general, function no.: 0.

Designation	Description	Range	Default
Ostart	Self-tuning start	0...1	
Status	Status 1	Single bit	

When self-tuning is running, status message State_Tune1 is generated (Orun = 1) and can be evaluated as single bit. Self-tuning can be switched off at any time with Ostart=0 via the interface. If a controller operating status with higher priority is requested whilst self-tuning is running, self-tuning is cancelled immediately and the controller changes to this operating status.

Function block controller type no.: 91, function tuning, function no. 5.

Designation	Description	Range	Default
State_Tune1	Status Tuning 1	Single bit	
Yoptm	Correcting variable during process at rest	-105...+105%	

Whilst self-tuning is active, the set-point can be changed. After finishing self-tuning successfully, the controller leaves the self-tuning status and switches over to automatic mode.

When self-tuning is started from the automatic mode, the stable correcting variable (Yoptm) is output and the controller waits, until the process is at rest.

With self-tuning start from the automatic mode, the actually adjusted manual correcting variable for „process at rest“ is output.

The process is at rest, when variable X is within a tolerance band of +/- 0,5% of span ($X_{100} - X_0$) during more than 60 seconds.

5.3 Priority 2 Tune, error

If controller self-tuning was finished with an error or cancelled, the controller switches to manual and outputs a constant correcting variable with the value of stable correcting variable YOptm. In this condition, the manual correcting variable cannot be changed.

The status must be confirmed by the operator previously by setting Ostart to 0.

There are 2 possibilities to finish self-tuning:

- 1 finishing self-tuning by Ostart = 0
stopping group self-tuning, if the controller participates in group self-tuning. Hereby, the stop signal is generated internally by the control function (see section Group self-tuning).
- 2 Coff, i.e. controller switch-off.

5.4 Priority 3 sensor break

With sensor break (variable X), the controller is set to manual and the pre-configured correcting variable is output (additional controller configuration C101_2). The correcting variable can be changed according to the selected configuration. When leaving the sensor break condition, the controller is initialized.

For the case that „no fail behaviour“ (no controller reaction) is configured (C101_2 = 6), the fail signal of input X is not evaluated. The configured substitute value of the input (Xfail from configuration C213) is always used as a measurement value for control (Xfail from configuration C213). Whether the input measurement is or is not in an error condition is unimportant.

Function block input type no.: 112, function MV/V1, function no. 1.

Abbr.	Description	Range	Default
XFail	Substitute value with sensor fail	-999...9999	0

5.5 Priority 5 manual

In this condition, the controller is switched over to manual mode bumplessly. (The last value of the controller correcting variable remains unchanged). An absolute or relative controller correcting variable can be pre-set, the rate of change (Ygrw_Is) is adjustable in two steps 0 = slow = 100% in 40 sec; 1 = fast = 100% in 20 sec. (With three-point stepping controller, only a relative correcting variable can be pre-set.)

Function block controller type no.: 91, function correcting variable, function no. 4.

Abbr..	Description	Range	Default
Yman	Absolute correcting variable	-105...+105 %	Y*)
dyman	Differential correcting variable	-210 +210 %	0
Yinc	Incremental correcting variable adjustment	0 = off 1 = on	0
Ydec	Decremental correcting variable adjustment	0 = off 1 = on	0
Ygrw_Is	Speed for incr. or decr. correcting variable adjustment	0 = slow 1 = fast	0

*) Yman is updated continuously by the controller, i.e. there is NO output step change.

5.6 Priority 7 Y_track

In status Y_Track, the controller provides tracking of the correcting variable to a pre-defined value. The function is handled internally in the controller. A detailed description of the operating principle is given in section 1 Cascade control.

5.7 Priority 8 controller off (high)

By activating a „switched off“ set-point, i.e. by determining a set-point of -32000 (for individual controllers).

Configuration is with Coff for 1 and with Sw/W2 for 2, in C190 for both.

Controller switch-off does not become effective by configuration, but only by a set-point of -32000.

Controller switch-off means switching to manual operation and output of correcting variable 0% for all outputs. In this mode, the correcting variable cannot be changed. Measurement value acquisition and the controllers themselves continue operating. This applies to all controller types.

Automatic - manual switch-over

According to configuration, automatic - manual switch-over via the interface is also possible. According to the signal priorities, the resulting controller statuses are as follows:

Priority				
8	7	5	3	
Controller off	Y track	Controller manual	Sensor failure	Controller status
0	0	0	0	Automatic
0	0	0	1	Sensor failure
0	1	0	0	Y-track
0	1	0	1	Y-track
0	0	1	0	Manual
0	0	1	1	Manual
0	1	1	0	Y track
0	1	1	1	Y track
1	x	x	x	Controller off

After a mains failure, the operating condition corresponds to the interface signals (EEPROM) stored last. The automatic/manual switch-over is bumpless. The last correcting variable calculated by the controller is output as effective manual value. With controller re-start, YHand is initialized with 0%.

With several simultaneous statuses, the status with the highest priority is effective.

The three methods for manual correcting variable adjustment are:

1. Absolute adjustment:
Adjustment of the absolute manual correcting value (Yman). This adjustment is not applicable to three-point stepping controllers.
2. Differential adjustment:
Adjustment of the value for correcting variable change (dYman).
3. Incremental adjustment:
Adjustment of values for incremental adjustment (positive direction Yinc, negative direction Ydec, Ygrw_l_s). Signal ...Ygrw_l_s selects the speed for incremental adjustment (slow = 40 sec,

fast = 10 sec for 100% adjustment). These specifications are only applicable to 2 and 3 point controllers. With 3-point stepping controllers, the speed is determined by the actuator.

Function block controller type no.:91, function correcting variable, function number 4

Symbol	Description	Range	Remarks
dYman	Differential correcting variable	-210...+210	
Yman	Absolute correcting variable	-105...+105	
Yinc	Incremental correcting variable adjustment	0	0 = off
		1	1 = on
Ydec	Decremental correcting variable adjustment	0	0 = off
		1	1 = on
Ygrw_Is	Speed for incr./decr. correcting variable adjustment	0	0 = off
		1	1 = on

6 Controller self-tuning (RSE)

For determining the optimum control parameters for a particular process, controller self-tuning is possible. Self-tuning can be started and finished from the automatic or the manual mode. It is also active with the start-up circuit configured.

6.1 Preparations for controller self-tuning:

DPID, PT, PD or P control action can be selected by the operator by switching off control parameters before self-tuning start.

Control action	switched off
DPID	nothing
PI	Tv=0
PD	Tn=0
P	Tn=0 and Tv=0

- Determine which parameter set shall be optimized (POpt)
- Determine the stable correcting variable Yoptm.
- Determine the correcting variable step change dYopt.
- Determine the „process at rest“ mode (main configuration C700)

6.2 Process at rest

„Process at rest“ monitoring is provided at any time. The process is at rest, if process value X is within a tolerance band of $\pm 0,5\%$ ($X_{100} - X_0$) during more than 60 seconds. If this band is exceeded, the timeout counter is set to zero and the timer must start again.

With extended „process at rest“ monitoring, monitoring is done for continuously changing input variable X (gradient) instead of a constant control variable.

6.2.1 Selecting the stable correcting variable

The stable correcting variable must be selected so that the separation of actual process value and effective set-point at self-tuning start is sufficient. The separation of process value and set-point must be higher than 10 % of $W_{110} - W_0$.

For some applications, identification with a known correcting variable step change can be recommendable. This dYopt is specified in % of the active correcting variable.

If e.g. the stable correcting variable is YOptm = 20% and a dYopt of 50% was selected, the effective correcting variable of 20 % changes by 50% to 70% at self-tuning start.

Function block controller type no. 91, function tuning, function no. 5.

Abbr.	Description	Range	Default
YOptm	Stable correcting variable	-100...+100 %	0
dYopt	Step height with identification	5...100 %	100
POpt	Parameter set to be optimized	0...1	0

6.2.2 Start from automatic mode

After starting, the controller outputs the stable correcting variable Y_{Optm} and waits, until the process is at rest. With „process at rest“ detected, self-tuning starts automatically. During this time, the set-point can be changed.

With the „process at rest“ condition met during control operation, the difference between stable correcting variable Y_{Optm} and last controller correcting variable can be considerable. In this case, waiting until the full „process at rest“ condition has elapsed is necessary, because this correcting variable change also implies a process value change within the watchdog time. The ideal case would be, if stable correcting variable Y_{opt} and last active controller correcting variable during automatic mode would be equal.

6.2.3 Start from manual mode

When switching over to manual mode, the correcting variable output last is taken over as manual correcting variable by the controller. This correcting variable can be changed according to requirements. At self-tuning start, this correcting variable is taken over and output as stable correcting variable Y_{optm} . Subsequently, the controller waits, until the „process is at rest“, and self-tuning starts automatically. If the process is already at rest at starting time, the normal waiting time of 60 s is omitted, if the last correcting variable was 5 to 10% of the stable correcting variable. Like in automatic mode, the set-point can always be adjusted.

After successful completion of self-tuning, the controller switches to automatic mode. Based on process characteristics Tu_1 , V_{max1} and Tu_2 , V_{max2} , the parameters for the required control action are calculated. DPID, PI, PD or P control action can be selected by the operator by switching off $T_n=0$ or $T_v=0$ before self-tuning start. The determined parameters are stored in selected parameter set PO_{opt} and are available via the interface.

When finishing self-tuning with an error, stable correcting variable Y_{Optm} is output, until self-tuning is finished via interface by the operator ($O_{start} = 0$).

6.2.4 Self-tuning start with heating (2-point and 3-point stepping controller)

After reaching „process at rest“, the process is stimulated with a correcting variable step change. Tu_1 and V_{max1} are determined from the process reaction measured, if possible, at the turning point of the step response. With controllers participating in group self-tuning, self-tuning start is described in „Group self-tuning of several controllers“.

6.2.5 Self-tuning procedure with heating and cooling processes: (3-point contr.)

At first, self-tuning is as with a „heating“ process. After the end of the heating attempt, the controller parameters are determined on the basis of the process characteristics. These parameters are used for lining out to the set-point, until „process at rest“ is reached again. Subsequently, a step change to cooling is output for determination of the controller cooling parameters using process characteristics Tu2 and Vmax2. Starting the cooling attempt with controllers which participate in group self-tuning is described in „Group self-tuning of several controllers“.

6.2.6 Set-point monitoring

For maintaining a safe process condition, monitoring for exceeded set-point is provided continuously. When exceeding a set-point, self-tuning is cancelled, an error message is output, the controller switches over to manual mode and stable correcting variable YOptm is output.

6.2.7 Group optimization of several controllers

With configuration C700_2, the controllers pertaining to a group can be classified. Only one group with up to 16 controllers is possible per instrument. Group self-tuning is started with the (instrument-specific) input Ostartg.

Function block instrument type - no.: 0, function general, function no. 0.

Abbr.	Description	Range
Ostartg	Self-tuning stop and start of all controllers	0 / 1

6.2.8 Group self-tuning start

Group self-tuning is started by setting signal Ostartg = 1. For group starting, all controllers must have reached the „process at rest“ condition. The self-tuning coordination function sets the start signals of individual controllers to start the relevant self-tuning procedures (RSE).

Independent of the valid controller status, the coordination function tries to start self-tuning of all group controllers. If starting is not permitted for a controller because of a higher priority status, the sequence control rejects the enquiry and resets signal Ostart to 0.

6.2.9 Group self-tuning stop

When control signal Ostartg is reset to 0 whilst group optimization is active, all active group optimizations are cancelled simultaneously. For this purpose, control signals Ostart of the individual controllers are set to 0 by the coordination function.

Group self-tuning of the individual control loops is finished as during individual self-tuning, whereby the relevant control signals Ostart are reset to 0. When all group self-tunings are finished, the control signal Ostart for group start is reset to 0.

6.2.10 Starting the heating attempt of all group controllers in common

When all controllers of the group for which self-tuning is running signal readiness for starting the heating attempt („process at rest“), the enable signal for the heating attempt is output simultaneously to all active optimizations of the group. Group controllers which signal faulty self-tuning do not prevent attempt enabling.

6.2.11 Common start of the cooling attempt for all 3-point heating/cooling controllers of the group

After the coordinator function has started self-tuning for the individual group controllers, no further coordination between controllers is provided.

Exception: If 3-point heating/cooling controllers participate in the attempt, the cooling attempt of these controllers is started in common by the coordinator function.

Enabling the cooling attempt start is done as follows:

When all 3-point heating/cooling controllers of the group for which self-tuning is running signal readiness to start the cooling attempt and all other group controllers have finished or cancelled self-tuning, the coordinator function enables the cooling attempt simultaneously for all active group self-tunings.

When starting a 3-point heating/cooling controller of the group by setting signal $O_{start} = 1$ individually via the interface, the cooling attempt is enabled immediately.

6.2.12 Signification of self-tuning messages

Messg e	Signification or error cause	Possible solution
0	No attempt was made, or attempt was cancelled by switching over to automatic mode	
1	<p>Cancellation: Wrong output action of correcting variable, X does not change in direction W</p>	Change controller output action
2	Finished: Self-tuning was realized successfully (turning point found, estimation safe)	
3	<p>Cancellation: The process variable does not react, or reacts too slowly (change of ΔX below 1% in 1 hour).</p>	Close control loop
4	<p>Finished: (low turning point) Cancellation: stimulation insufficient (turning point found;estimation unsafe.)</p>	Increase set-point step change dY_{opt}
5	<p>Cancellation: Self-tuning cancelled due to risk of exceeded set-point</p>	Increase separation between process value (X) and set-point (W) when starting.
6	Finished: Self-tuning cancelled due to risk of exceeded set-point (turning point not reached so far, estimation safe)	

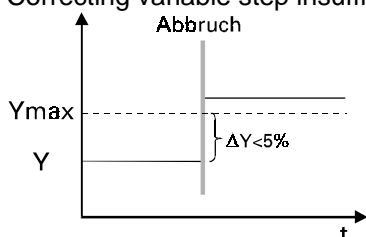
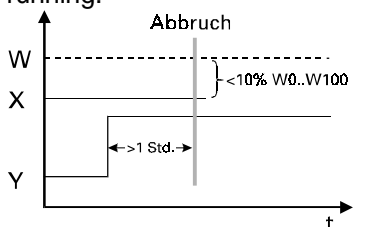
<p>7</p>	<p>Cancellation: Correcting variable step insufficient, $\Delta Y < 5\%$</p> 	<p>Increase Y_{max}, or set Y_{optm} to a lower value.</p>
<p>8</p>	<p>Cancellation: Set-point reserve insufficient or set-point exceeded whilst PiR monitoring is running.</p> 	<p>Change stable correcting varia- ble Y_{optm}</p>

7 Controlled adaptation

„Controlled adaptation“ is provided for cases in which the controller characteristics must be changed during control operation. Two parameter sets can be switched over via interface or via a digital control signal. The two parameter sets are adjusted with default values (see table of parameter sets) and can be changed or selected via the interface.

With self-tuning, determination which parameter set shall be optimized is possible. (POpt). Thereby, determining the optimum parameter set for the individual operating statuses and switching over by the relevant switch-over criterion are possible.

Function block controller type no.:91, function tuning, function number 5

Abbr.	Description	Range	Default
ParNr	Effective parameter set number	0...1	
POpt	Parameter set to be optimized	0...1	

7.1 Control function parameters

Dependent of instrument version, the default parameters marked with x are adjusted.

Parameter	Signaller		2-pnt contr.	3-pnt contr. heat. cool.	Three- point stepping contr.	Range	Default
	1 output	2 outputs					
Xp1			x	x	x	0,1...999,9	100
Xp2				x		0,1...999,9	100
Tn1			x	x	x	0...9999	10
Tv1			x	x	x	0...9999	10
T1			x	x		0,4...999,9	5
T2				x		0,4...999,9	5
xsh1				x		0,0...999,9	0
xsh2				x		0,0...999,9	0
xsh					x	0,2...999,9	0,2
Tm					x	10...9999	30
Tpuls					x	0,1...999,9	0,3
xsd1	x	x				0,1...999,9	1
LW		x				-999...9999	-32000
Xsd2		x				0,1...2,0	1
Ymin			x	x		0...100 -100...+100	0...-100
Ymax			x	x		0...100 -100...100	0 100
Y0			x	x		0...100 -100...100	0...100
W0	x	x	x	x	x	-999...9999	0
W100	x	x	x	x	x	-999...9999	900
W2	x	x	x	x	x	-999...9999	100
Grw+	x	x	x	x	x	0...9999,---	----
Grw-	x	x	x	x	x	0...9999,---	----
Grw2	x	x	x	x	x	0...9999,---	----

8 Signaller

Signal function

The signal function is a controller function and must be specified for each individual controller by configuration C100_3.

This configuration is applicable to processes with small T_u and low V_{max} . The possible process variations are determined using formula

$$X_0 = X_{max} * T_u/T_g + X_{sd} = v_{max} + T_u + X_{sd}$$

The signal function corresponds to limit signalling, whereby the set-point represents the limit value. The trigger point is symmetrical to the set-point. Hysteresis X_{sd1} is adjustable.

The signaller with two outputs has an additional „high and low trigger point“, the separation of which from the set-point is adjusted by means of parameter LW (including parity sign). The following figures show the static characteristics for output actions „inverse“ and „direct“.

Determination of the controller output action is during configuration C101_4.

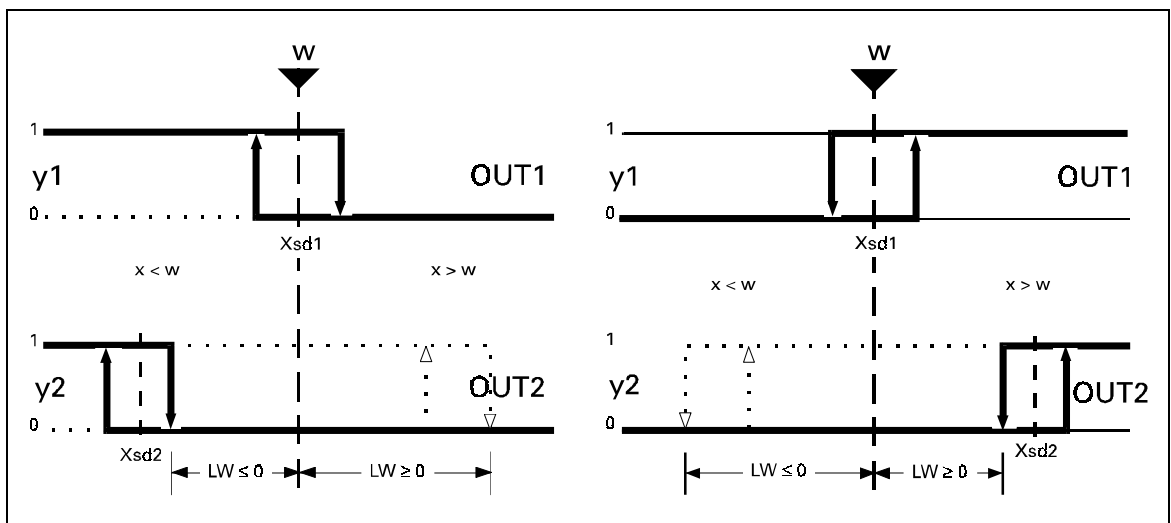

The parameters required for the signaller are transmitted from:

Function block controller type no.:91, function algorithm, function no. 3.

Abbr.	Description	Range	Default
Xsd1	Switching difference signaller	0,1...+9999	1
LW	Trigger point separation additional contact	-999...9999	0
Xsd2	Switching difference additional contact	0,1...+9999	1

9 Two-point controller

The parameters required for this controller are transferred:

Function block controller type no.:91, function paramset x, function number 6 and 7.

(function number 6 = parameter set 1; function number 7 = parameter set 2)

Abbr.	Description	Range	Default
Xp1	Proportional band 1	0.1...999,9%	100 %
Tn1	Integral time 1	0...9999sec	10 sec
Tv1	Derivative time1	0...999sec	10 sec
T1	Min. cycle time	0,4...999,9 sec	5 sec

The parameters required for this function block are transferred from:

Function block controller type no.:91, function correcting variable, function no. 4.

Abbr.	Description	Range	Default
Ymin	Min. correcting variable limiting	-100...+100 %	0 %
Ymax	Max. correcting variable limiting	-100...+100 %	100 %
Y0	Working point for correcting variable	-100...+100 %	0 %

Determination of the controller output action is in configuration C101_4.

Cycle time T1 corresponds to the minimum cycle time (time in seconds) at 50 % duty cycle.

With optimization according to the control behaviour, the hints given in table Parameter characteristics must be followed.

Parameter characteristics (two-point/three-point controller)

Parameter	Adjustment	Control and line-out of disturbances	Start-up behaviour
Xp1	higher	increased damping, slower line-out of disturbances	slower reduction of duty cycle and possible overshoot of set-point
	lower	reduced damping, fast line-out of disturbances, increase Xp if process oscillates	fast reduction of duty cycle, increase Xp, if line-out oscillates
Tn	higher	increased damping, slower line-out of disturbances	slow change of duty cycle
	lower	reduced damping, faster line-out of disturbances, increase Xp if the stability becomes too low	faster change of duty cycle
Tv	higher	reduced damping and faster response to disturbances	early switch-off downscale of set-point with possible overshoot
	lower	increased damping, with slower response to disturbances	late switch-off downscale of set-point with possible overshoot

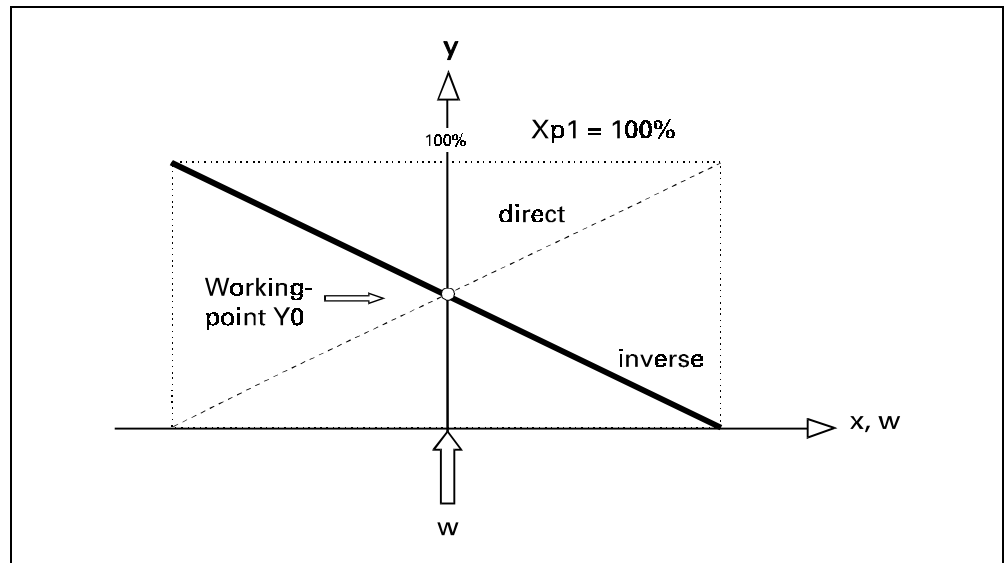

PD-action ($T_n = 0$)

The working point is determined with $X=W$ output $Y = 0 + Y_0$.

For keeping the process constant, a certain amount of energy dependent of set-point is necessary. Consequently, there is a permanent control deviation which is higher with increased X_{p1} .

DPID-action ($T_n > 0$) Using the I-action, line-out is without permanent control deviation.

The static characteristic of the two-point controller is identical with the one of the continuous controller. The difference is that a duty cycle instead of a linearly changing current signal is output.

Working point Y_0 and cycle time T_1 at 50% duty cycle are adjustable. The min. switch-on or switch-off time is approx. 63 ms.

10 Three-point controller DPID

The parameters required for this controller are transferred from:

function block controller type no.:91, function paramset x, function no. 6,7.

Abbr.	Description	Range	Default
Xp1	Proportional band 1	0,1...999,9 %	100 %
Tn1	Integral time	0...9999 sec	10 sec
Tv1	Derivative time	0...9999 sec	10 sec
T1	Min. cycle time 1	0,4...999,9 sec	5 sec
Xp2	Proportional band 2	0,1...999,9 %	100 %
Tn2 *)	Integral time 2	0...9999 sec	10 sec
Tv2 *)	Derivative time 2	0...9999 sec	10 sec
T2	Min. cycle time 2	0,4...999,9 sec	5 sec

Function block controller type no.:91, function correcting variable, function no. 4.

Abbr.	Description	Range	Default
Ymin	Min. correcting variable limiting	-100,,,100	-100
Ymax	Max. correcting variable limiting	-100...100	100
Y0	Working point for correcting variable	-100...100	0

Function block controller type no.:91, function algorithm, function no. 3

Abbr.	Description	Range	Default
Xsh1	Neutral zone	0,0...999,9 %	0
Xsh2	Neutral zone	0,0...999,9 %	0

Determination of the controller output action is in configuration C101_4.

Cycle times T1 and T2 correspond to the minimum cycle times with 50% duty cycle. For optimizing according to the control action, the hints given in table: Parameter characteristic must be followed.

PD/PD action ($T_n = 0$)

The positioning range extends from 100% heating (switching output 1) to -100% cooling (switching output 2). The proportional bands must be matched to the different heating and cooling rates. For keeping the process constant, a defined amount of energy dependent of set-point is required. It causes a permanent control deviation, which increases with higher $X_p(1,2)$.

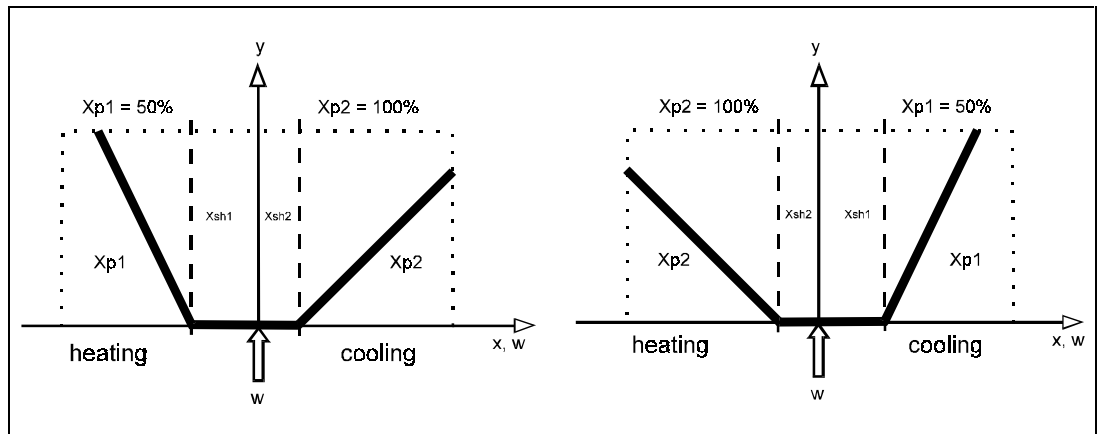

The static characteristic for inverse and direct output action with $T_n = 0$ is shown in the figures. Direct/inverse switch-over only causes an exchange of the outputs for „heating/cooling“.

The terms „heating“ and „cooling“ are used as substitutes for all similar processes (batching acid/lye, ...). The neutral zone is separately adjustable for the switching points. (X_{sh1} , X_{sh2}) and need not be symmetrical to the set-point.

DPID/DPID action

The I action ($T_n > 0$) can be used for line-out without permanent offset. The proportional bands must be matched to the different heating and cooling rates and can have different X_p ranges. Transition from trigger point 1 (heating) to trigger point 2 (cooling) is dependent of the neutral zone X_{sh1}, X_{sh2} . With the process value within the neutral zone, the actual correcting variable remains unchanged, until it is again out of this zone.

11 Three-point stepping controller

In order to match the adjusted Xp1 to the motor actuator travel time, the travel time Tm must be adjusted. The smallest positioning step is 0,1sec.

Adjusting the neutral zone

With excessively frequent output switching, the neutral zone Xsh can be increased. Note, however, that an increased neutral zone will cause a decrease of the control sensitivity. Therefore, we recommend to optimize switching frequency (wear of external relays/contactors and motor actuator) and control sensitivity.

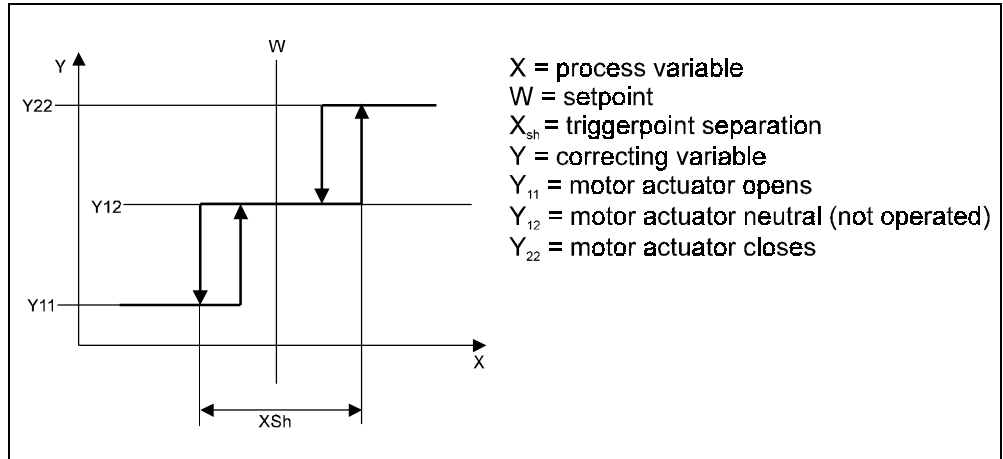

Parameter adjustment effects of three-point stepping controller:

Parameter	Setting	Effect
Xp1	higher	Shorter positioning steps, increased stability and slower line-out of disturbances
Xp1	lower	Longer positioning steps, reduced stability and faster line-out of disturbances
Tn	higher	Longer pauses between positioning steps, improved stability, and slower line-out of disturbances
Tn	lower	Shorter pauses between positioning steps, reduced stability, and faster line-out of disturbances
Tv	higher	Positioning steps larger and reduced stability
Tv	optimal	Optimum stability

In the figure below, the static characteristics of a three-point stepping controller are shown as configured inversely and directly. The hysteresis shown in this figure is virtually without importance, however, it can be calculated from the adjustable pulse length Tpuls <10ms.

$$Xsh = (Tpuls/2) * 0,1 * (Xp/Tm) \text{ Units: } Xsh = \text{sec}, Tpuls = \text{sec}, Xp = \%, Tm = \text{sec}$$

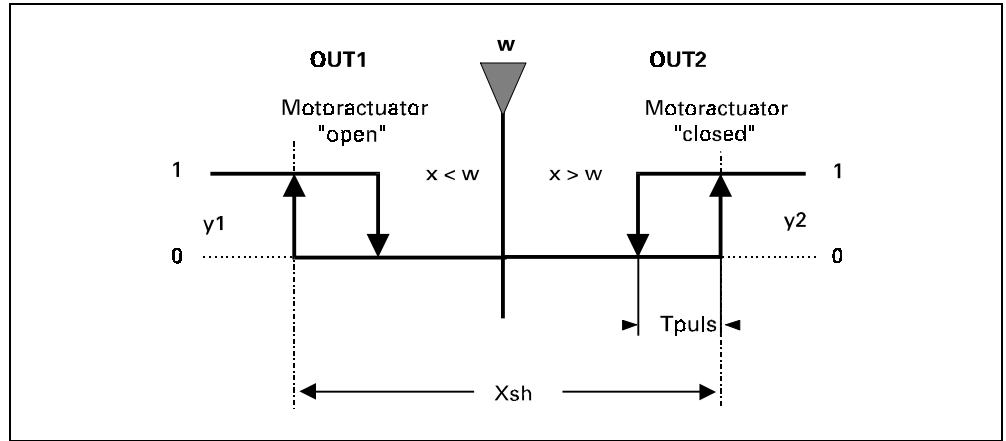

Configuration example: room temperature control by means of a motor-actuated valve.

Input	PT100 set-point range 10 to 60°C
Controller structure	three-point stepping, inverse output action, differentiate X_w
Alarms	sensor failure or measurement value alarm, measurement value alarm relative limit contact high and low X_w alarm output via rel. 1 -15K ...+15K $X_{sd1} = 0,5K$ high high and low low alarm output via rel.2 -4,5K...+4,5K $X_{sd1} = 0,5K$ sensor failure: output on relay 3 action with sensor failure: close valve.

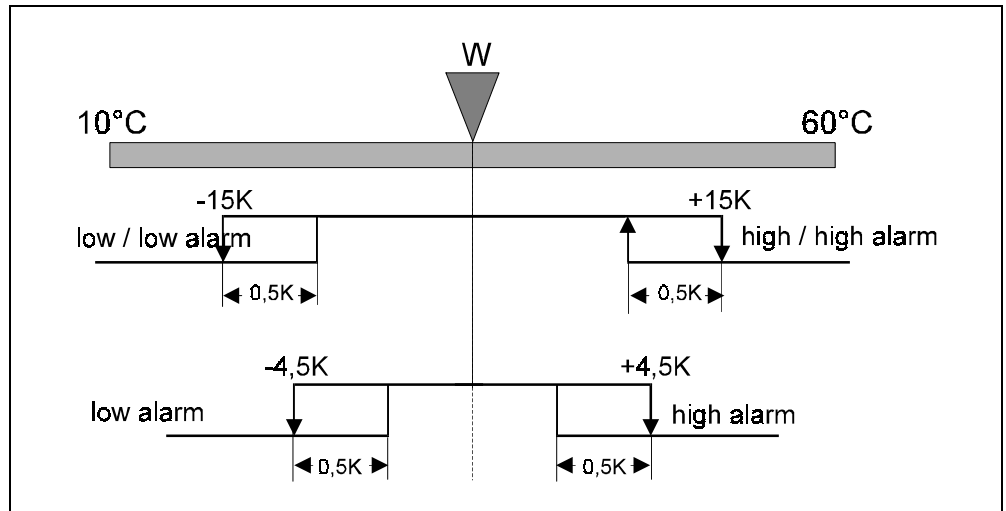

Input configuration:

Sensor type	main configuration C200 resistance thermometer type 20, unit 1
Set-point range	function block controller type no.:91, function set-point - processing function no.: 1 $W_0 = 10, W_{100} = 60$

Controller structure:

Three-point stepping controller controller configuration C101 CMode 0,
CDiff 0, Cfail 1, CAnf 0
Controller configuration C100 CFunc 07,
CType 0, Wfunc 0

Function block controller type no.:91, function algorithm function no.: 3
Xsh neutral zone in % related to X0...X100 from main variable Input 1
Tm actuator travel time in sec
Tpuls min. pulse length in sec

Function block controller type no.:91, function paramset x function no.: 6,7
Xp1 Proportional band 1 in % related to X0...X100 from main variable
Input 1
Tn1 integral time in sec
Tv1 derivative time in sec

Alarms:

Relative limit contact main configuration C600 Src 02, Fnc 2, DestFail 3,
main configuration C601 DestLL 1, DestL 1,
DestH 2, DestHH 2
Function block alarm type no:46, function general function no.: 0
LimL = -15, LimH = +15 Xsd1 = 0,5 LimLL = -4,5,
LimHH = +4,5

12 Cascade control

For cascade control, one master and one or several slave controllers the set-point of which is the analog control output of the master are used.

As long as cascade control remains at 2 levels (1 master controller with 1-level slave controllers), any combination is possible: from 1 master with 15 slaves up to 8 masters with 8 slaves.

Main configuration C100 determines, if a controller is a master or a slave. In configuration C180 (section 19.2.3), the external set-point source for the slave controller is specified for determination of the cascade structure. One master controller can provide the external set-point for several slaves.

Cascades extending over more than one unit are not possible.

12.1 Configuration of a simple cascade with one master and one slave

Each of the 16 controllers can be configured as a master or as a slave.

Master configuration:

C100_43 = 02 (2-point/master controller with output Ypid)
 C100_1 = 0 (set-point)
 C180_3 = 0 (no Wext)

Slave configuration:

C100_43 any
 C100_1 = 1 set-point / cascade)
 C180_3 = 1 - 16 (Wext = Ypid of master controller 1 - 16)

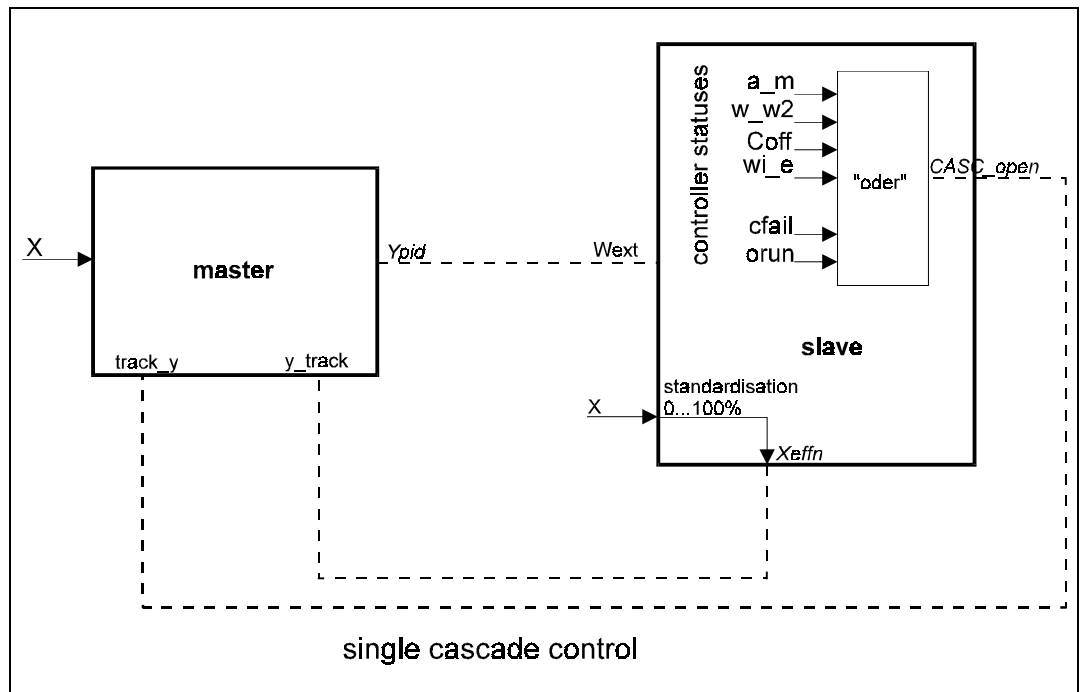

In the example shown above, 4 groups each with one master and one slave are possible. The controllers of a cascade are connected internally via configuration and communicate with each other. Additional input and output scaling is not necessary.

Special slave controller input signals for cascade operation:

Wext: The master provides a continuous output signal Ypid in 0 ... 100%, which is connected with the internal Wext input of the slave as configured in C180.

xeffn: Process value X of the slave controller is standardized to 0 ... 100% and copied back to the mater as output signal Xeffn, if internal signal CASC_open is set (cascade is interrupted).

12.2 Controller behaviour with switch-over

12.2.1 Switching over the master from:

Automatic to manual	= no effects on slaves
W to W2	= no effects on slaves
Outputs	= Ypid = 0, Wext of slave is also = 0, otherwise no effects.
Sensor break	= Ypid dependent of configuration upscale, down scale or neutral.
Start controller self-tuning	= Y pid is set to various values by self-tuning.

12.2.2 Switching over the slave :

The following switch-over operations set signal CASC_open internally, whereby signalling that the cascade is interrupted is provided (CASC_open is not accessible externally):

- automatic to manual
- W to W2
- output off
- sensor break
- Wext to Wint (via interface)
- Start controller self-tuning

12.3 Interrupting the cascade operation

During each cycle, the master controller evaluates the slave controller status. With cascade interruption, the master changes from automatic to manual operation internally.

For this, the process value standardized by the slave is used for continuous adjustment Yhand of the master and output at Ypid to avoid saturation effects of the master in the open cascade. Adjusting the manual value is not possible in this mode. When the cascade is closed again by returning to the initial slave mode, the master changes from manual to automatic mode bumplessly, if it was in the automatic mode before opening the cascade.

12.4 Cascade control example with up to 15 slave controllers

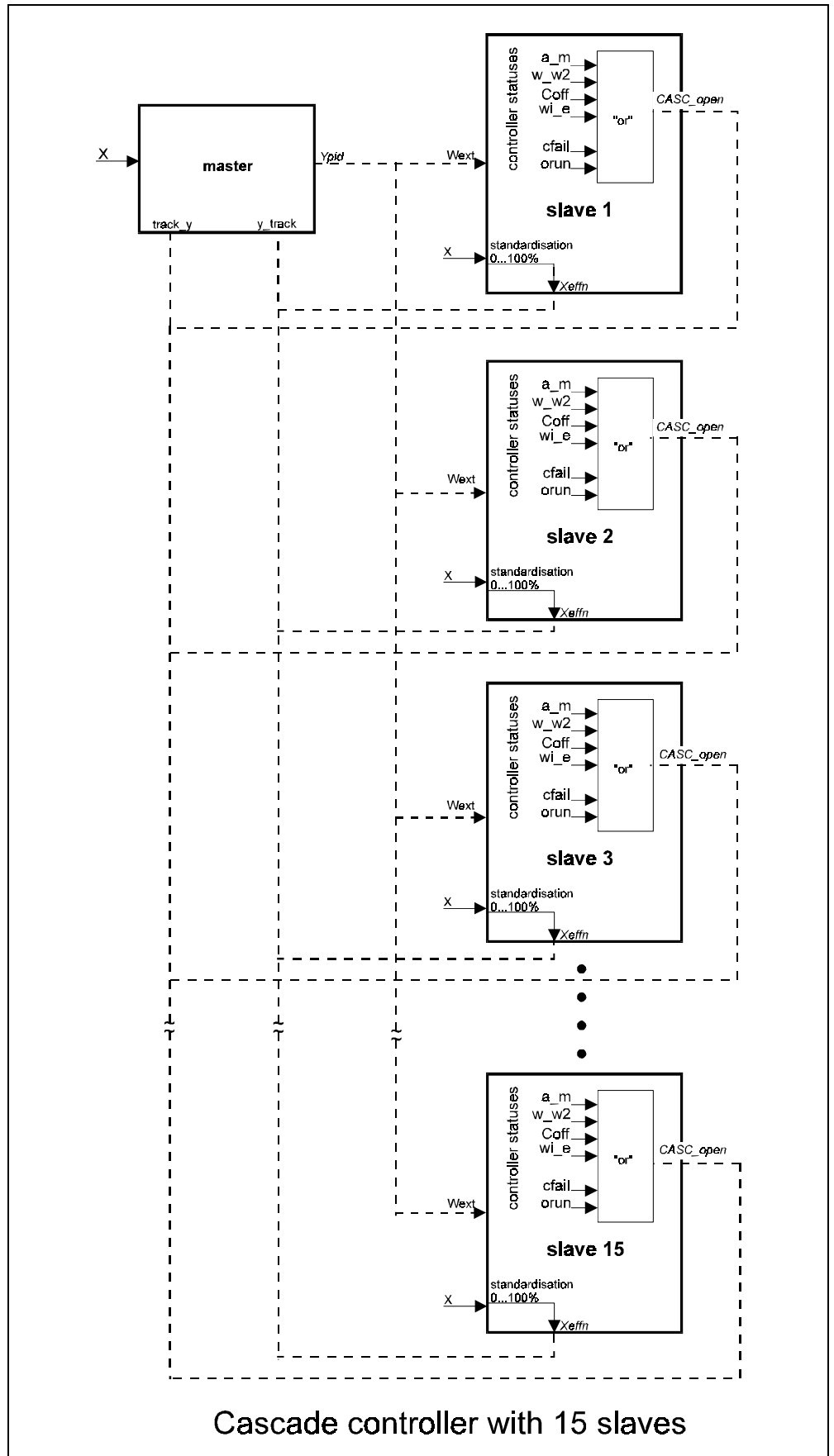

For special applications, connection of up to 16 slave controllers to a master can be necessary. In this case, the master controller correcting variable is used as slave controller set-point. The slaves control the connected loop individually with the adjusted parameters.

Master controller configuration:

C100_43	= 02	(master with output Ypid)
C100_1	= 0	(set-point)
C180_3	= 0	(no Wext)

Slave controller configuration:

C100_43	= any	
C100_1	= 1	(set-point / cascade)
C101_2	= 5	(last mean Y)
C180_3	= x	(Wext = Ypid from master channel x=1-16)

The operating principle is as with simple cascade control.

With slave switch-over or cascade interruption, however, note that:

When the cascade is opened due to an event of any slave, the process value standardized by the slave is used for adjustment Yhand of the master and output at Ypid. This concerns all connected slave controllers. If several slave controllers are in this condition simultaneously, adjustment is to the value which was copied into the master controller input by the slave concerned last.

13 Start-up circuit

The start-up function is a controller function and must be specified for each individual controller by configuration C101_1 = 1 (with start-up circuit). The start-up function is only active with the controller in automatic mode. Another operating mode causes cancellation of the start-up function.

Abbr.	Description	Range	Default
Ya	Max. correcting value	5...100 %	5 %
Wa	Start-up correcting value	-999...9999	95
TPa	Start-up holding time	0...9999 min	1 min

After controller switch-on with $X < Wa < W$, correcting variable Y is limited to Ya . Consequently, the process value runs with a constant $Y = Ya$ towards set-point Wa . Start-up holding time TPa starts 1K below this value. After elapse of this time, line-out to set-point W is provided. If the process value drops by $> LCA$ (40K, fixed) below set-point Wa due to a trouble, the procedure starts again. With $W < Wa$, W is used as start-up set-point and no holding time is used.

Self-tuning start does not cause cancellation of the start-up circuit. Self-tuning runs in a particular start-up circuit condition. When starting the self-tuning from status ANFAHR_LIMIT_Y, it runs with limited correcting variable. When starting from another condition, correcting variable limiting is not provided. After self-tuning end, the start-up circuit switches to one of the other conditions dependent of actual conditions.

The following start-up circuit conditions are possible

ANFAHR_OFF:	control is to W in normal operation
ANFAHR_LIMIT_Y:	control with start-up set-point, correcting variable limiting effective, cycle time $T01/4 > 0.4$ sec
ANFAHR_HALTEZEIT:	control with start-up set-point for the holding time duration
ANFAHR_TUNE:	optimization busy

Status ANFAHR_OFF

If the process value drops by more than 40K below the active start-up set-point (Wa), switch-over to status ANFAHR_LIMIT_Y occurs. The start-up function is handled again.

Status ANFAHR_LIMIT_Y

The controller is operated with max. correcting variable limiting $Y = Ya$. If the controller correcting variable is lower, it is given priority. Moreover, the minimum cycle time is reduced to $\frac{1}{4}$ of the adjusted cycle time.

With a process value of less than 1K below the active start-up set-point $Wa < W$, switch-over to status ANFAHR_HALTEZEIT occurs. Start of start-up holding time.

With a process value of less than 1K below the active start-up set-point Wa and $Wa > W$, the holding time is omitted and switch-over to status ANFAHR_OFF occurs (control to set-point W during normal mode).

Status ANFAHR_HALTETZEIT

If the process value drops by $> LCA$ (40K, fixed) below W_a , switch-over to status ANFAHR_LIMIT_Y occurs. If the set-point for normal mode (W) falls below the required start-up set-point (W_a) due to a set-point change, the holding time is cancelled and switch-over to status ANFAHR_OFF occurs.

With the required holding time PT_a elapsed, the start-up circuit is finished and switch-over to status ANFAHR_OFF occurs.

Status ANFAHR_TUNE

When self-tuning is finished, switch-over to another status is according to the actual conditions.

With the actual process value above the actual start-up set-point, switch-over to status ANFAHR_OFF occurs.

With a control deviation $< 1K$ and start-up set-point (W_a) $<$ than the actual set-point (W), switch-over to status ANFAHR_HALTEZEIT occurs.

With a control deviation $< 1K$ and a start-up set-point (W_a) $>$ the actual set-point (W), the holding time is omitted and switch-over to status ANFAHR_OFF occurs.

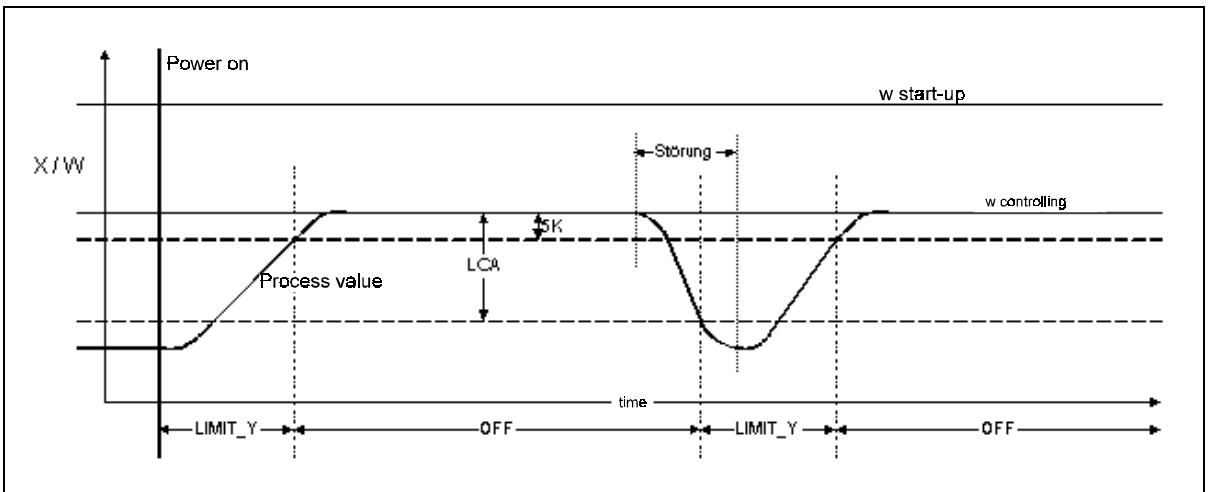
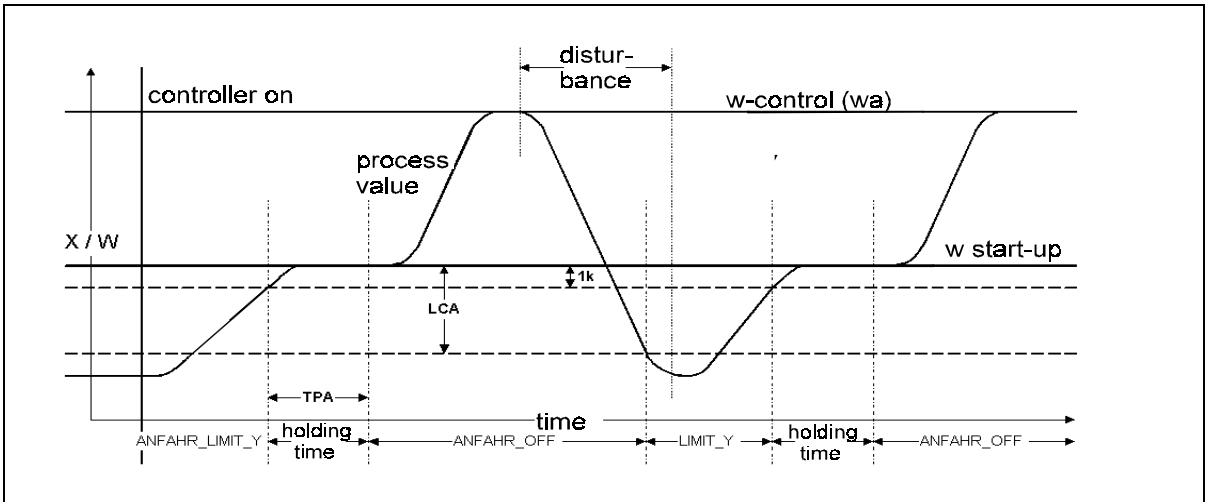

14 Mean value formation for the output hold function

Mean value formation is effective only with configuration C101_2 = 5. The required parameters are transferred to:

function block controller type no.:91, function correcting variable, function no. 4.

Abbr.	Description	Range	Default
Yh	Max. mean value of correcting variable	5...100 %	5,0 %
LYh	Limit for mean value formation	0,1...10,0	1,0

Mean value formation is a controller function and must be specified by configuration C101_2 for each individual controller. With sensor failure, an average value is output and the controller switches over to a kind of „manual mode“, in which the correcting variable can be adjusted manually. After removal of the sensor failure, return to the automatic mode is automatic.

Mean value calculation

If the control deviation is within LYh (limit for mean value formation), the arithmetic mean value of mean and new controller correcting variable is calculated.

Mean value = (mean value + new correcting variable) / 2.

If the control deviation is below the required limit value (LYh) during min. 60 s and the limits of Yh, Ymax. and Ymin are met, the mean value is output as correcting variable. Manual adjustment is possible.

Inverse / direct controller operation

Configuration C101_4 determines how the controller processes control $xw = x-w$. During „inverse operation“, the correcting variable increases, when the control deviation becomes positive. The process value is higher than the effective set-point.

Differentiating X/XW

Configuration C101_3 determines how to differentiate control variable or control deviation.

C101_3 = 0 differentiates control deviation xw

C101_3 = 1 differentiates process value X (dx/dt).

15 Alarm processing

For each controller, four trigger points are adjustable (without determination of names and abbreviations!). However, using the terms used in the drawing is purposeful.

The switching hysteresis is equal for all four trigger points.

As alarm signal source for each controller, various sources which can be monitored with up to four values are possible. For each controller, only one alarm source can be monitored, whereby distribution of the four monitored values to several alarm sources is not possible.

Sources for the alarms can be:

Xeff	the effective process value (control variable) as a relative or absolute alarm.
Xeff_fail	A failure in the sensor circuit, sensor break or short circuit.
Xw	Control deviation alarm, a defined control deviation amount was exceeded.
Ypid	Correcting variable alarm, when the correcting variable leaves the defined range.

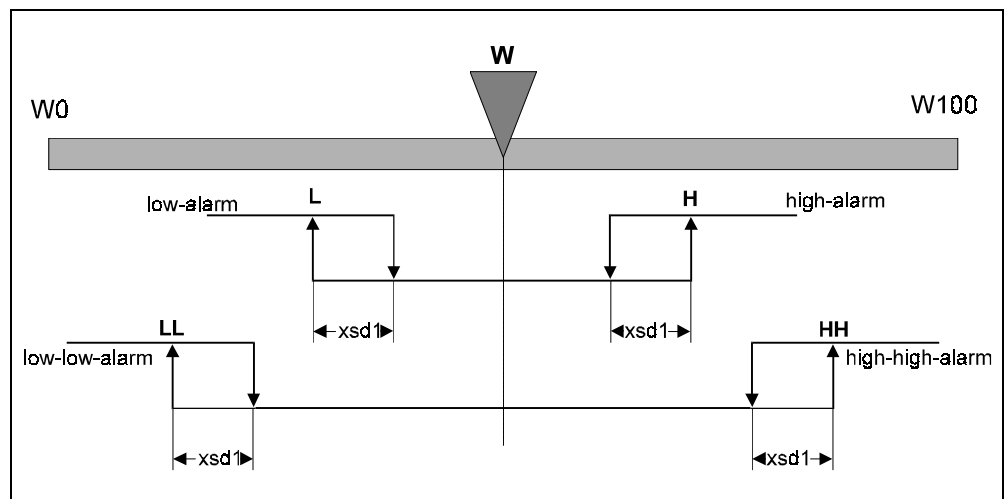

Configuration word C600 and C601 determines which signal shall be monitored by the alarm function and how to use the alarm functions.

Function block alarm type no.:46, function general, function no. 0.

Abbr.	Description	Range	Default
LimL	Low alarm trigger point	-999...9999	-32000
LimH	High alarm trigger point	-999...9999	-32000
LimLL	Low low alarm trigger point	-999...9999	-32000
LimHH	High high alarm trigger point	-999...9999	-32000
Xsd	Alarm switching difference	0...9999	0,5

16 Configuration

16.1 General

The KS 816 controller configuration is described in this section. The function required for the application is selected from a large variety of functions. The basic structure for an application solution is determined for configuration. Non-selectable digits are marked with „0“.

16.2 Main configuration groups

Main configuration groups are:

	Description	Ranges of configuration words
1	Controller function	C100...C151
2	Input function	C180...C499
3	Output function	C500...C599
4	Alarm function	C600...C699
5	Controller self-tuning	C700...C799
6	Additional functions	C900...C999

16.2.1 C100 Main controller configuration (adjustable for each controller)

This main group determines the controller structure and function and is the starting point for structuring the controller for a specific application. Main configuration is with configuration word C100. After determining this word, no further adjustments are required for a large number of applications. Additional function matching is possible by means of configuration word C105.

	C100			
Digit	4	3	2	1
Description	Cfunc		Wfunc	
Default	02		0	o
Determination	always			

CFunc: Controller **F**unction, control behaviour)

- 00: signaller 1 output
- 01: signaller 2 outputs
- 02: 2-point controller (or master controller with output Ypid slave controller set-point)
- 03: 3-point controller (heating switching and cooling switching)
- 07: 3-point stepping controller

Wfunc: (Set Point (**W**) **F**unction)

- 0: Set-point $W_{eff} = W_{int}/W_2$
- 1: Set-point/cascade $W_{eff} = W_{int}/W_{ext}$ (with slave controller: $W_{ext} = Y$ from master)

16.2.2 C101 Additional controller configuration (*adjustable for each controller*)

The following additional adjustments are possible via additional controller configuration:

	C101			
Digit	4	3	2	1
Description	Cmode	CDiff	Cfail	CAnf
Default	0	1	1	0
Determination	always			

Cmode: (Controller output action **mode**)

- 0: inverse increasing input variable generates falling output variable
- 1: direct increasing input variable generates increasing output variable

Cdiff: (Controller **d**ifferentiation)

- 0: differentiate Xw (differentiate control deviation)
- 1: differentiate X (differentiate process value)

Cfail: (Controller behaviour with main variable sensor **f**ailure)

- 0: neutral (controller outputs switched off as in de-energized condition)
- 1: Ypid = Ymin the correcting variable is set to the min. value. 1)
- 2: Ypid = Ymax the correcting variable is set to the max. value. 1)
- 5: Ypid = Ymit output of calculated mean correcting variable
Simultaneous switch-over to manual mode, after which the correcting variable can be changed manually.
(Ypid is the actual controller correcting variable.)
- 6: **no** fail behaviour No reaction to sensor failure. The controller does not react on the input sensor failure. The configured substitute input value (Xfail from C213) is always used as measurement value for control, independent of whether or not the input measurement is in error condition.

Canf: (start-up circuit)

- 0: no start-up circuit
- 1: with start-up circuit

1) Ymin and Ymax are determined separately for each controller in function block controller type no. 91, function correcting variable, function number 4.

16.2.3 C180 Analog signal allocation

Control signals for set-point processing (adjustable per controller)

	C180			
Digits	4	3	2	1
Description	SWext			
Default	0	0	0	0
Determination	always			

SWext: (source for the external set-point of the slave controller)

- 0: no Wext
- 1: Wext = Y from master controller 1
- 2: Wext = Y from master controller 2
- 3: Wext = Y from master controller 3
- 4: Wext = Y from master controller 4
- 5: Wext = Y from master controller 5
- 6: Wext = Y from master controller 6
- 7: Wext = Y from master controller 7
- 8: Wext = Y from master controller 8
- 9: Wext = Y from master controller 9
- 10: Wext = Y from master controller 10
- 11: Wext = Y from master controller 11
- 12: Wext = Y from master controller 12
- 13: Wext = Y from master controller 13
- 14: Wext = Y from master controller 14
- 15: Wext = Y from master controller 15
- 16: Wext = Y from master controller 16

16.3 Inputs

The signal inputs for the selected controller configuration are selected in this main group. As with control function configuration, an important part of applications can be covered by determining the main configuration.

Signal input 1/IN1...IN16 (main variable)

The main variable is configured in this main group. These signal inputs are universal inputs, for which extensive configuration is possible.

16.3.1 C200 Main configuration

The main configuration word determines sensor type and physical quantity (adjustable per controller). If necessary, additional input configurations can be determined with additional configuration C201 to 214.

	C200			
Digit	4	3	2	1
Description	Type			Unit
Default	01			1
Determination	always			

Type: (sensor type)

Thermocouple:

00	Type L 0 ... 900°C	05	Type R 0 ...1760°C
01	Type J 0 ... 900°C	06	Type T 0 ... 400°C
02	Type K 0 ...1350°C	07	Type W0 ...2300°C
03	Type N 0 ...1300°C	08	Type E 0 ...1000°C
04	Type S 0 ...1760°C		

Resistance thermometer:

20: Pt 100 99,9 ...850,0°C

Standard current signal

30 0...20mA
31 4...20mA

Voltage:

34: -100 ... +100 mV
35: -10 ... +10V

Unit:

0: fixed with type = 34
1: °C
2: °F

16.3.2 Input scaling

Input scaling is possible with direct current (mV and V) and direct voltage input (0/4mA). By input scaling, other physical quantities are allocated to the electric input voltages for (span) start and end. (e.g. 0mV = 0l/h and 80mV = 1000l/h; 0mV = -500mbar and +100mV = 500mbar) Scaling must be done separately for each controller.

C201 input scaling start

Span start adjustment X0

	C201			
Digits	4	3	2	1
Description	X0			
Default	0			
Determination	only with type = 34			

X0: (physical value at 0%)
numeric value -999 ... 9999

16.3.3 C202 Span end input scaling

Adjustment of span end value X100.

	C202			
Digit	4	3	2	1
Description	X100			
Default	0			
Determination	only with type = 34			

X100: (physical value at 100%)
numeric value -999...9999

16.3.4 C205 Additional configuration

Via additional configuration (for inputs), modification or matching of the default setting for the signal input dependent of sensor type is possible (adjustable per controller).

	C205			
Digits	4	3	2	1
Description	Fail	STk	XKorr	Reserve
Default	1	1	0	0
Determination	always	only with type=00...16 (C200)	always	fixed

Fail: (signal behaviour with sensor failure)
1: Upscale (signal is set to a high value)
2: Downscale (signal is set to a low value)
3: Substitute value (substitute value is defined in C213)

STk: type of temperature compensation)

0: not effective
1: internal TC
2: external TC(fixed TC value is specified in C210!)
3: TC of controller 16
Remote cold junction reference measurement. Input 16 can be used so that it works as an input of the temperature sensor of a remote cold junction reference. The thermocouples of individual channels are connected with compensating lead up to a common cold junction reference. Copper lead can be used between cold junction reference and KS 816. The 16th input is used for measuring the temperature of this cold junction reference and for correcting the input voltage accordingly. If the sensor of controller 16 is a thermocouple, a compensating lead must be taken up to KS 816. If the sensor is a resistance thermometer, copper lead can be used. For reasons of accuracy, resistance thermometers in 3-wire connection should be used.

Xkorr: process value correction enabling)

0: not effective
1: with process value correction (adjustable via parameters x1in, x1out, x2in, x2out)

16.3.5 C210 External temperature compensation

	C210			
Digits	4	3	2	1
Description	Tkref			
Default	0			
Determination	only with type = 00...18 (C200) and Tf = 2 (C205)			

Tkref: (external TC)
Value : -99...100 °C or °F

16.3.6 C213 Sensor failure

	C213			
Digits	4	3	2	1
Description	Xfail			
Default	0			
Determination	only with Fail = 3 (C205)			

Xfail: substitute value with sensor failure)
Value: -99 ... 9999

16.3.7 C214 Filter time constant

	C214			
Digits	4	3	2	1
Description	Tfm			
Default	0,5			
Determination	always			

Tfm: filter time constant (of measurement value processing)
value: 999,9 sec

16.4 Configuration examples

16.4.1 Thermocouple

With a thermocouple, temperature compensation type, TC value and signal behaviour in case of sensor break can be determined. The behaviour is determined with configuration word C205.

Configuration of: C200, C205, C210, C213, C214

16.4.2 Resistance thermometer

With a resistance thermometer, the signal behaviour with sensor break/short-circuit can be determined in configuration word C205.

Configuration of: C200, C205, C213, C214

16.4.3 Voltage and standard current

With these input variables monitoring for break or short circuit is not purposeful and therefore not possible.

16.4.4 C600 Type of alarm

The alarm type is configured in C600 (adjustable for each controller).

	C600			
Digits	4	3	2	1
Description	Src		Fnc	DestFail
Default	02		2	0
Determination				

Src: (alarm signal source)

- 00: no source alarms switched off
- 01: Xeff absolute limit contact
- 02: Xw relative limit contact
- 03: Weff absolute limit contact
- 04: Ypid absolute limit contact

Fnc: (alarm function)

- 0: no alarm alarm switched off
- 1: sensor fail
- 2: sensor fail or measuring value alarm
- 3: sensor fail or measuring value alarm with suppression in case of set-point changing or start-up
- 4: measuring value alarm
- 5: measuring value alarm with suppression in case of set-point changing or start-up.

16.4.5 C700 controller self-tuning (RSE, Tune)

The type of controller self-tuning and the type of controlled adaptation can be adjusted (adjustable for each controller).

	C700			
Digits	4	3	2	1
Description	OMode	OCond	OGrp	OContr
Default	0	0	0	0
Determination				

- Omode:** (controller self-tuning)
 0: based on determined process characteristics Tu and Vmax.
- Ocond:** (process at rest mode)
 0: grad(x) = 0 process at rest is detected, when x is constant
 1: grad(x) < 0 = const. & inverse: process at rest is detected, when x decreases regularly with a controller with inverse action.
 grad(x) > 0 = const & direct: process at rest is detected, when x increases regularly with direct action.
 2: grad unequal to 0 process at rest is detected with x changing regularly. In this case, continuation of this constant change during identification must be ensured.
- Ogrp:** (assignment to group self-tuning)
 0: no group self-tuning (only individual self-tuning possible)
 1: group self-tuning
- Ocntr:** (controlled adaptation mode)
 0: no function
 2: switch-over only via interface
 3: switch-over via interface or control input

16.4.6 Additional functions

16.4.6.1 C900 Baudrate of COM1 PC interface

The Baudrate of serial interface COM1, (PC interface, Western socket) is configured. (adjustable per instrument).

This interface is a pure „point-to-point“ connection, which does not require addressing.

Unless there are other important reasons, the default setting of this function should remain unchanged.

	C900			
Digits	4	3	2	1
Description	Baud			
Default	04			
Determination	always			

- Baud:** (Baudrate)
 01: 2400 Bd 03 9600 Bd
 02: 4800 Bd 04 19200Bd

16.4.6.2 C901 Address of COM1

The address for COM1 is adjusted in C901.

C901				
Digits	4	3	2	1
Description	Adr			
Default	0			
Determination	always			

Addr: (interface address)
0 ... 99

16.4.6.3 C902 Baudrate of COM2 bus interface

The Baudrate of serial interface COM2, (bus interface, sub-D connector) is configured. (adjustable for each instrument).

C902				
Digits	4	3	2	1
Description	Baud			
Default	0	RS=03; CAN=01; Profi=automatic		0
Determination	always			

Baudrate-setting:

KS816 RS

01: 2400Bd
02: 4800Bd
03: 9600Bd
04: 19200Bd

KS 816 CAN

01: 20kBd
02: 125kB
03: 500kBd
04: 1MBd

05: 10kBd
06: 50kBd
07: 250kBd
08: 800kBd

KS 816 Profi:

No adjustment is necessary. Selection is automatic.

16.4.6.4 C903 Address of COM2

The address for COM2 is adjusted in C903.

C903				
Digits	4	3	2	1
Description	Adr			
Default	RS=0; CAN=1; Profi=126			
Determination	always			

Addr: (interface address)

KS 816-RS
0 ... 99

KS 816-CAN
1 ... 127

KS 816-Profi
0 ... 126

16.4.6.5 C904 Mains frequency

The mains frequency for optimum interference suppression of analog inputs is configured (adjustable for each instrument).

	C904			
Digits	4	3	2	1
Description	Frq			
Default	0			
Determination	always			

Frq: (mains frequency)

0: 50 Hz

1: 60 Hz

